

IR Receiver Module for PCM Remote Control Systems

Description

The SDR438-TR is a dual lens miniaturized SMD-IR receiver for infrared remote control systems. Two PIN diodes and preamplifier are assembled on lead frame, the epoxy package is designed as IR filter.

The demodulated output signal can directly be decoded by a microprocessor. The main benefit is the reliable function even in disturbed ambient and the protection against uncontrolled output pulses.



Features

- Photo detector and IC in one single package
- TTL and CMOS compatible
- Output active low
- Enhanced immunity against disturbance from lamps
- No occurrence of disturbance pulses at the output
- Suitable burst ≥ 15 cycles/burst
- RoHS compliance

Special Features

- TV
- Audio Video equipments
- Home appliances with remote control systems

Applications

TV, VTR, Acoustic Devices, Air Conditioner, Car Stereo Units, Computers, Interior controlling appliances, and all appliances that require remote controlling

Block Diagram

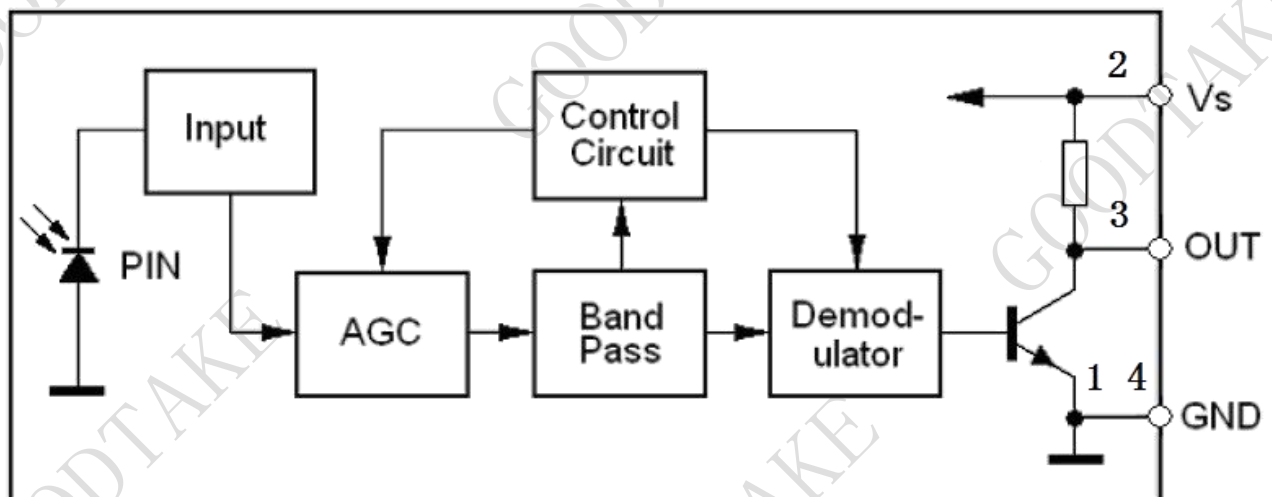

Applications Circuit

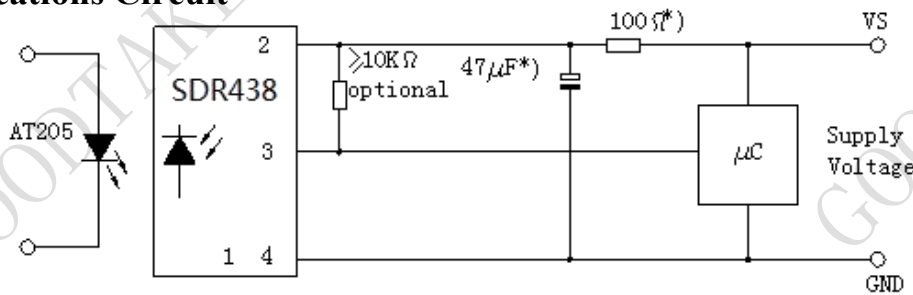

*) recommended to suppress power supply disturbances

* Note: Power line filter is recommended - resistor 47 ohm with 47uF capacitor

Absolute Maximum Ratings

Tamb = 25 °C

Parameter	Test Conditions	Symbol	Value	Unit
Supply Voltage	(Pin 2)	Vs	-0.3...6.0	V
Supply Current	(Pin 2)	Is	3	mA
Output Voltage	(Pin 3)	Vo	-0.3...6.0	V
Storage Temperature Range		Tstg	-25...+85	°C
Operating Temperature Range		Tamb	-25...+85	°C
Power Consumption		ptot	18	mW
Soldering Temperature	t ≦ 5s, 1 mm from case	Tsd	260	°C

Electrical & Optical Characteristics

Tamb = 25 °C Vs = 5.0V

Parameter	Test Condition	Symbol	Min	Typ	Max	Unit
Supply current	Vs = 5V, Ev = 0	Is		0.45	0.80	mA
	Vs = 3V, Ev = 0		0.15	0.35		
Operating Voltage	(Pin 2)	Vs	2.7	3.0	5.5	V
Transmission distance	IR diode AT205, IF = 400mA, Ev = 0		22	25		m
The minimum distance between the remote control and the receiver	IR diode AT205, IF = 400mA		0.3			m
Output Voltage High	Vs = 5V	VOSH	4.5			V
Output Voltage Low	IOSL = 2 mA, f = fo, tp/T = 0.4	VOSL			400	mV
Peak Wavelength	Internal IR filter	λ		940		nm
Carrier frequency	Internal BPF	fc		38		kHz
Output pulse width	Input burst = 600μS	Tp	400		800	μS
Angle of 1/2 Distance	Horizontal Half angle	1/2θ		±45°		Deg

1) Standard test signal at 38kHz carrier, Ton / Toff = 600μS / 600μS

Test Condition:

1. Test signal for output pulse width

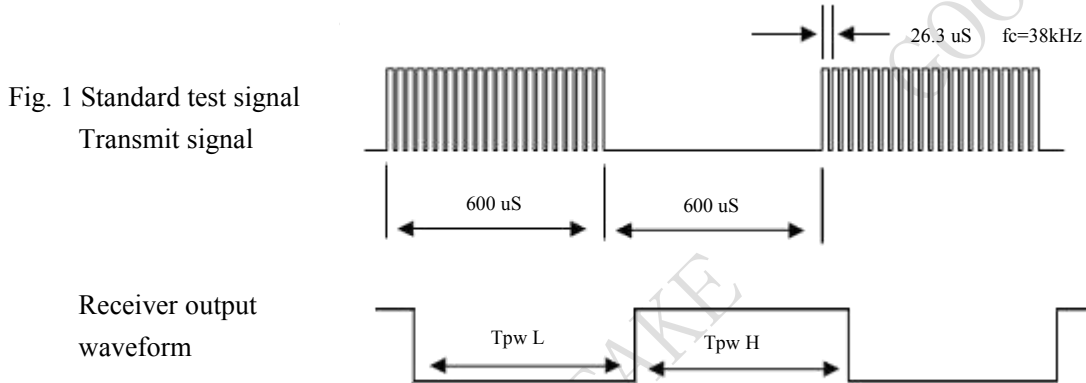

2. Arrival distance

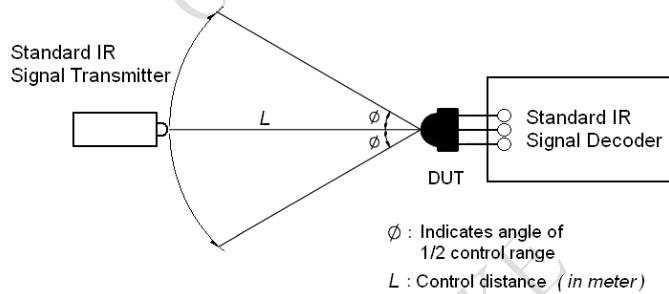

Test condition for measuring the control distance

3. Suitable Data Format

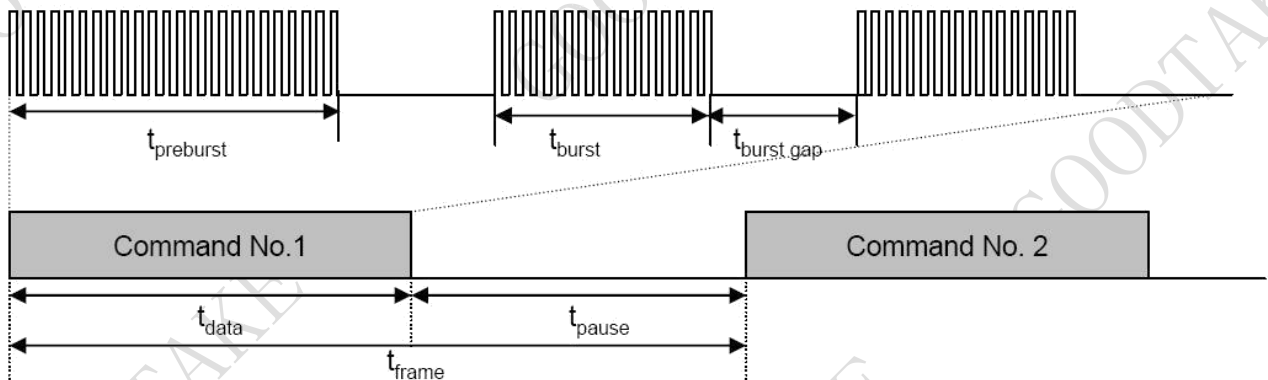

- Minimum burst length (t_{burst}) of 15 pulses per burst
- Minimum burst gap time ($t_{burst.gap}$) 20pulse
- Minimum data pause time (t_{pause}) > 22msec
- Suitable data format are : NEC Code, RC 5, RC 6 Toshiba

Characteristics Curve ($T_{amb}=25^{\circ}C$ unless otherwise specified)

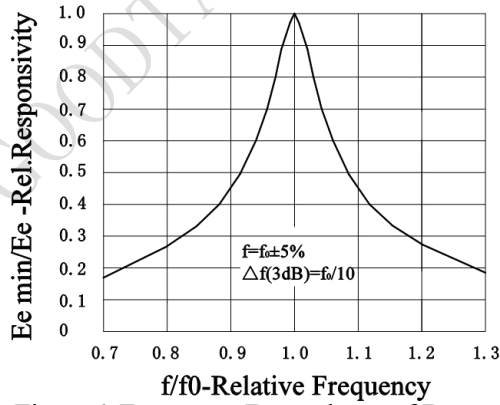

Figure.1-Frequency Dependence of Responsivity

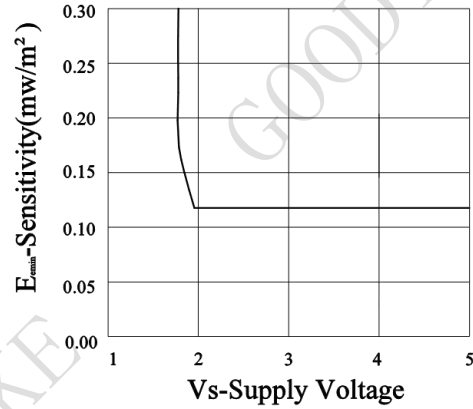

Fig.2-Sensitivity VS. Supply Voltage

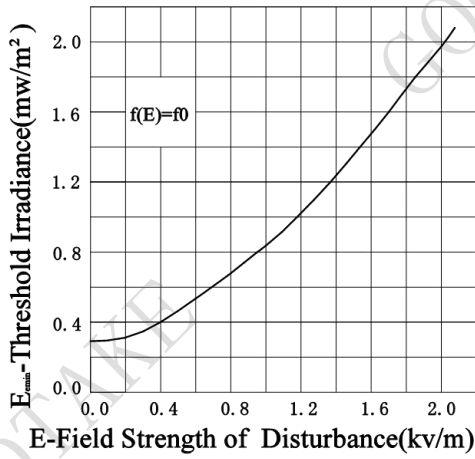

Figure.3- Sensitivity vs.Electric Field Disturbances

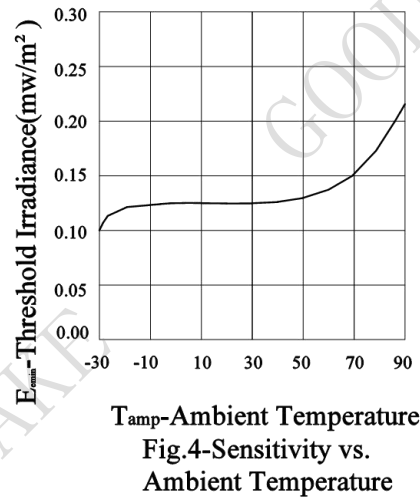

Fig.4-Sensitivity vs. Ambient Temperature

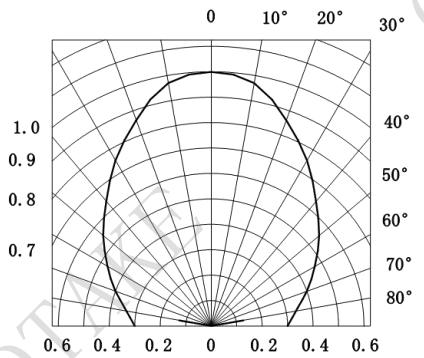

Fig.5-Vertical Directivity

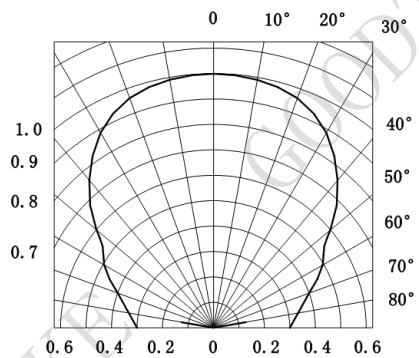

Fig.6-Horizontal Directivity

Reliability Test

TEST ITEM	TEST CONDITION	TEST TIME	SAMPLE NUM	OK NUM
High Temperature Storage	Ta=+85°C	t=240H	22	22
Low Temperature Storage	Ta=-25°C	t=240H	22	22
Electro Static Discharge	HBM C=100pF, R=1.5kΩ, 2kV,	each pin test once	22	22
High Temperature/Humidity*	Ta=+85°C, 90%RH	t=240H	22	22
Heat Cycle*	-25°C~+85°C(0.5H)	20cycle	22	22

Note : *(electro-optical characteristics) shall be satisfied after leaving 2 hours in the normal temperature

Package Outline

Dimensions in mm: General tolerance ± 0.3mm

1#

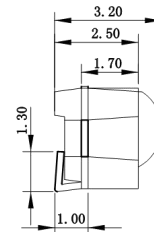
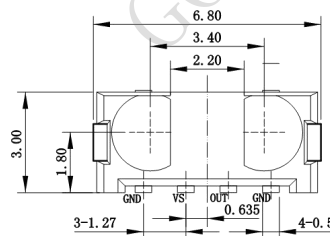

Pick and place area. TR taping

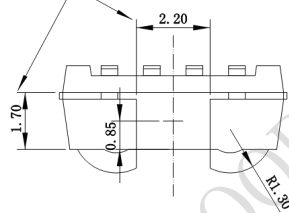

Proposed pad layout from component side (for reference only)

1. GND
2. VS
3. OUT
4. GND

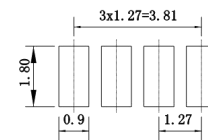

2#

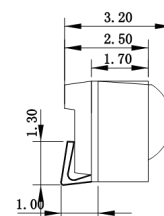
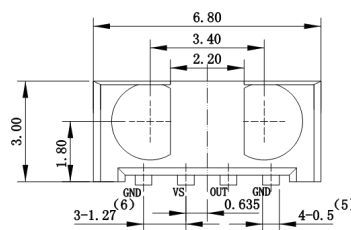

Pick and place area. TR taping

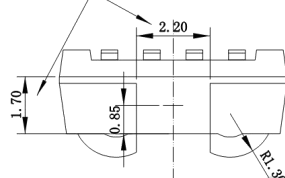

Proposed pad layout from component side (for reference only)

1. GND
2. VS
3. OUT
4. GND

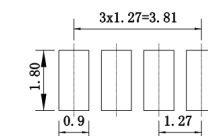

Taping Specifications

(1) **Shape and dimensions of reels:** unit in mm

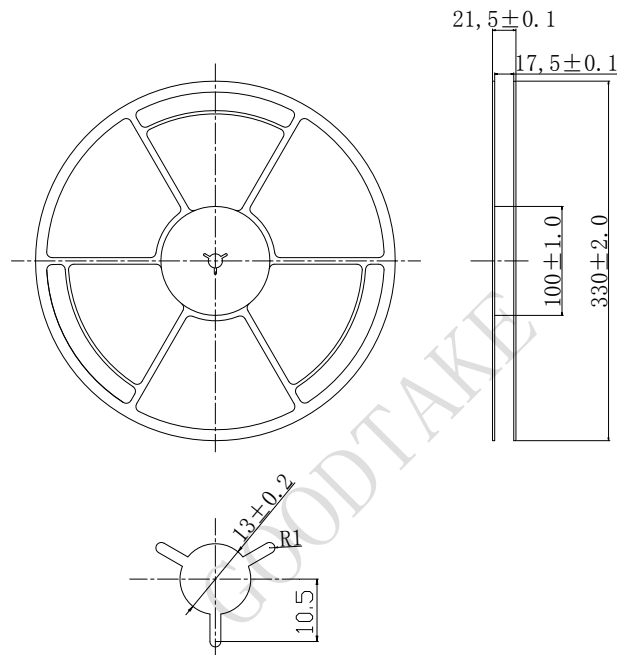

(2) **Dimensions of tape**

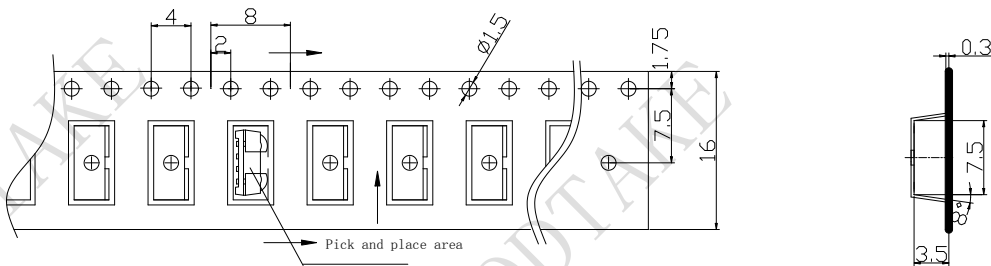

(3) **Configuration of tape**

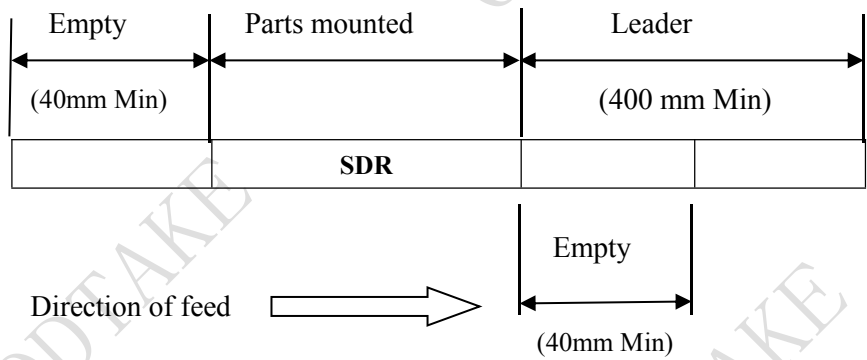

(4) **Quantity :** 2,000pcs. / reel

Reflow Soldering profile

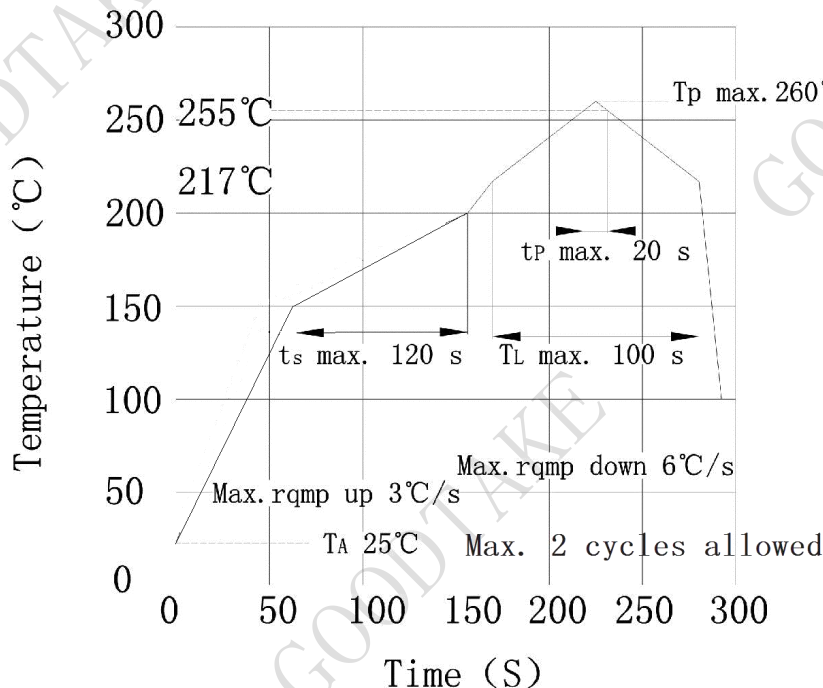

Soldering Iron: With rating 25watt or below, ESD protected iron, maximum 350°C & complete soldering within 3 seconds. Do not put force on device while soldering, and leave 2 seconds or more before apply heat to another terminal pad.

Pb-free solder : Pb-free soldering paste, melting temperature: $230\sim 235^\circ\text{C}$

Compositions : Sn/Ag 3%/ Cu 0.5%

Antistatic Dry Packing

Opto devices in SMD package may be sensitive to moisture. Devices are taped & reeled, sealed in antistatic bag with silica gel desiccants.

Do not open the sealed moisture-proof bag before ready to use. If sealing is void, baking treatment may be required.

Storage

Shelf life – Devices should be stored in its original packing, in a controlled environment of temperature less than 40°C and relative humidity below 90%.

Suggested shelf life is 12 months.

Floor life – After opening of the sealed package, the reeled devices should be consumed within 72 hours, in a controlled environment with such condition of $T_{amb} < 30^\circ\text{C}$, $RH = < 60\%$.

Remaining unused parts should be stored in DRY BOX.

Drying (Baking Process) -

If original packing is voided (such as faded silica gel or exceeded storage time), baking treatment should be performed with the following conditions:-

Dry Box chamber : $T = 40^\circ\text{C} \pm 5^\circ\text{C}$, $RH < 1\%$, drying time = 192hours minimum.